

“Thermal Cube”

Custom-built Heat Flux Sensor

Specifications and Construction

MR. RAZIM REFAI

MR. SHAMMAWI ANDERSON

DR. ANDRÉ MCDONALD

Table of Contents

1. Introduction	2
1.1 Specifications [1].....	2
1.2 Materials of Construction.....	2
2. Thermal Cube Construction and Assembly.....	3
2.1 Aluminum Block	3
2.2 Thermocouples	4
2.3 Thermal Cube Field Stand.....	5
4. Data Analysis.....	8
4.1 Errors.....	9
5. Maintenance of the sensor	10
6. Additional Considerations	10
7. Limitation of Liability	10
8. Engineering Drawings [2]	11
8.1 Aluminum Block	12
8.2 Main Housing.....	13
8.3 Cover	14
8.4 Leg Pole.....	15
8.5 Field Stand.....	16
8.6 Thermal Cube Stand: Assembled.....	17
9. Voltage-to-Temperature Conversion.....	18
10. References.....	20

1. Introduction

The heat flux sensor (hereafter referred to as “Thermal Cube”) is a simple and effective device used to measure the thermal energy that is released during high heat load applications and that is incident on the sensor at a given location. The sensor uses a one-dimensional, finite-length scale, transient heat conduction model to estimate energy per unit area (in kW/m²) that is incident upon it.

The data obtained from the Thermal Cube will enable determination of the following:

- Transient heat flux
- Time to ignition (of vegetative fuels)

The device is convenient to use due to its portability and small size. It is also inexpensive when compared to other heat flux sensors that are commercially available.

1.1 Specifications [1]

Particulars	Specifications
Working Range (kW-m ⁻²):	10 to 65
Response Time:	8 seconds @ 50 kW-m ⁻²
Emissivity:	~ 0.95
Field of view:	180 degrees
Cooling water temperature:	N/A
Cooling water flow:	N/A

1.2 Materials of Construction

The following components are required to fabricate the Thermal Cube:

1. 6063-T6 Aluminum block
2. Type-J, 30 gauge thermocouples (three)
3. M-board insulation
4. High-temperature black spray paint
5. Carbon steel

A data acquisition system will be required to collect the temperature data measured by the thermocouples.

2. Thermal Cube Construction and Assembly

2.1 Aluminum Block

1. Waterjet cut a rectangular 6063-T6 aluminum block to dimensions of 50.8 mm x 63.5 mm x 25.4 mm (2 in x 2.5 in x 1 in).
2. Drill four 2 mm (0.08 in) diameter holes on the top surface of the aluminum block as shown in Figure 1. The holes correspond to locations at $x = 3.2$ mm (2 holes), $x = 12.7$ mm and $x = 22.2$ mm as shown in Section 8.1 of this manual. The distance between the two holes at $x = 3.2$ mm is 6.4 mm.
3. Spray the front and back sides of the block with high-temperature black spray paint (Krylon 1618 BBQ and Stove Paint, The Sherwin-Williams Company, Cleveland, OH, USA).

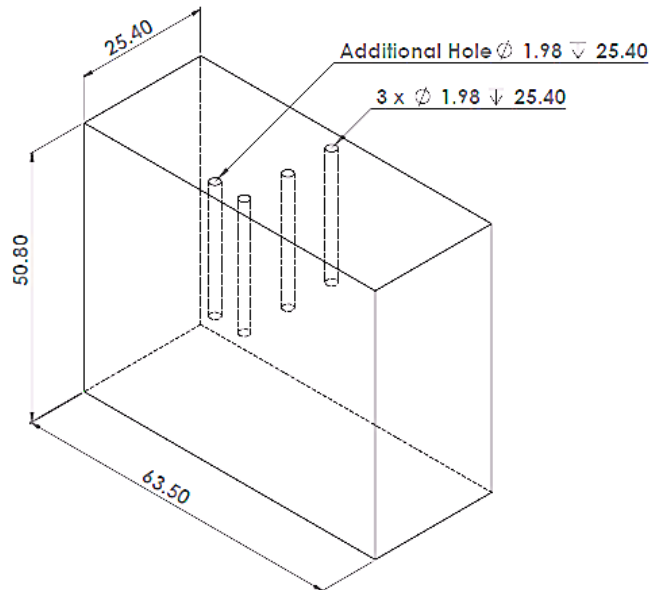

Figure 1: Drawing of Aluminum block (all dimensions are in mm) [2]

2.2 Thermocouples

Three J-Type thermocouples are used in the Thermal Cube to obtain transient temperature measurements.

1. Strip the insulation from the ends of the thermocouples using a wire stripper.
2. Solder the iron and constantan wires of one thermocouple (hereafter called the “regular thermocouple”) at any one end. The iron and constantan wires being soldered should be from the same end of the thermocouple wire.
3. The remaining two thermocouples are wired according to Figure 2 to obtain the “differential thermocouple.” Solder the iron and constantan wires of each thermocouple at any end of the respective thermocouple wires to obtain the “front face thermocouple” and “back face thermocouple.”
4. At the other ends of the two thermocouples, solder the constantan wires from each thermocouple to each other to complete the connection.
5. Ensure that the thermocouples have been soldered properly. Test the thermocouples with a known temperature and a data acquisition system to ensure proper functionality.
6. Insert the soldered end of the regular thermocouple in the “additional hole” that is indicated in Figure 1.
7. Insert the “front face thermocouple” in the front face hole as shown in Figure 3.
8. Insert the “back face thermocouple” in the back face hole as shown in Figure 3.

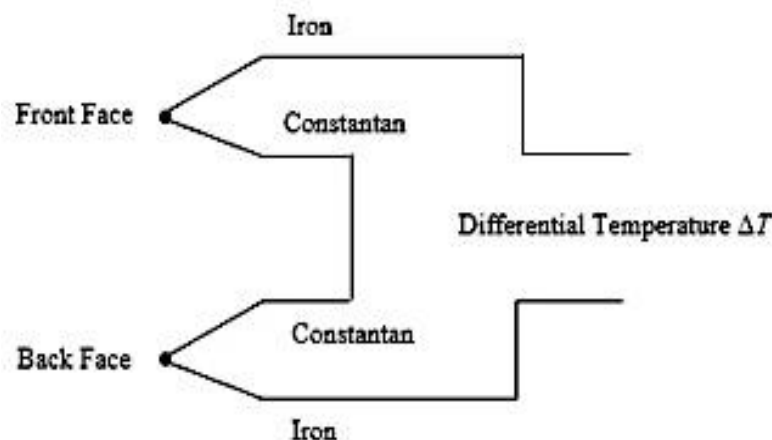

Figure 2: Differential Thermocouple Wiring Arrangement [2]

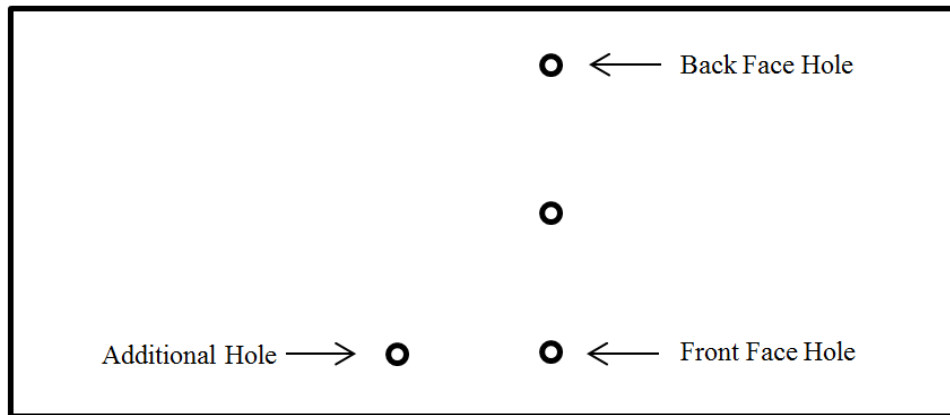

Figure 3: Top View of Aluminum Block

2.3 Thermal Cube Field Stand

The Thermal Cube Field Stand consists of a “main box”, “cover”, “leg pole” and “base plate”. It serves as housing for the aluminum block, thermocouple wires, and the data acquisition system.

1. Use carbon steel to fabricate the “main box”, “cover” and “leg pole”. The engineering drawings for each of these components are available in Section 8 of this manual.
2. Weld the unthreaded end of the “leg pole” to the bottom surface of the “main box.”
3. Use steel to fabricate the “base plate” based on the engineering drawing present in the Section 8 of this manual.
4. Place the “base plate” on a horizontal surface and screw the threaded end of the leg pole (with the main box welded on) on to the base plate.
5. Adjust the height of the “leg pole” (if required) by unscrewing the nut and bolt present on the “leg pole.” Upon extending the inner pole, screw back the nut and bolt in place.
6. Insulate the inside surfaces of the “main box” as well as the “cover” with M-board insulation (M-board, Industrial Insulation Group, Augusta, GA, USA) by press-fitting the M-board against the walls.
7. Place the aluminum block in the “aluminum block holder” (as shown in Figure 5) of the “main box” such that its front surface faces away from the “main box” and the surface containing the thermocouples is on top.

8. Ensure that the thermocouple wires are routed through the slit (shown in Figure 5) that is present at the top surface of the “aluminum block holder” and into the interior of the “main box.”
9. Place the data acquisition system in the “main box” (as shown in Figure 6) and connect it to the thermocouples.
10. Set the data acquisition system to read temperature values for the regular thermocouple and to read voltage values for the differential thermocouple.
11. Close the “main box” with the “cover.”



Figure 4: Thermal Cube Field Stand



Figure 5: Slit for routing of thermocouples in the Main Box

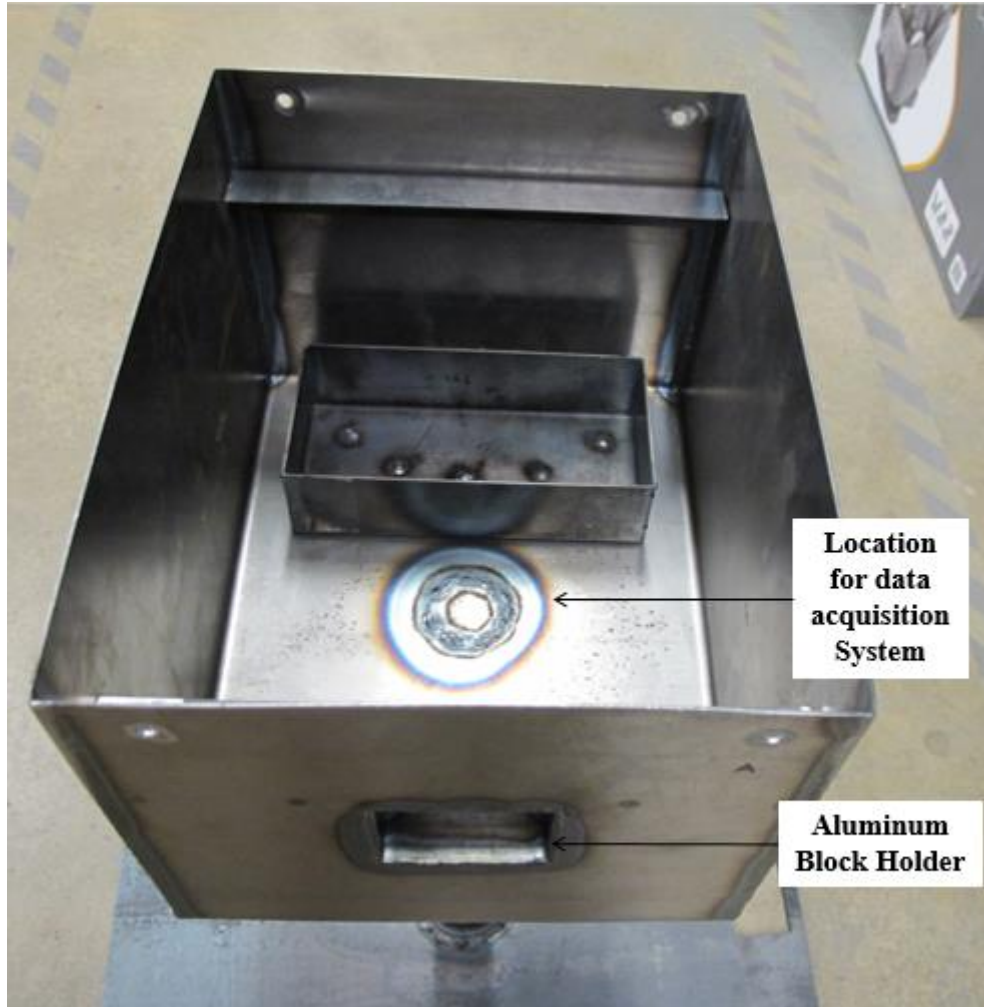

Figure 6: Main box of the Thermal Cube Field Stand

4. Data Analysis

1. Obtain the temperature and voltage readings from the data acquisition system.
2. The temperature reading from the regular thermocouple gives the front face temperature $T(d,t)$, where d is the depth into the sensor where the thermocouple is located (shown in Section 8.1) and t is time.
3. Convert the voltage reading from the differential thermocouple to a temperature value by using a voltage-temperature conversion equation available in the Section 9.). This temperature value gives the differential temperature ΔT :

$$\Delta T = T(d,t) - T_1(t), \quad (4-1)$$

where $T_1(t)$ is the temperature of the back face of the sensor. Use Eq. (4-1) to calculate $T_1(t)$.

Use the aforementioned temperature values, that is ΔT , $T(d,t)$, and $T_1(t)$ in Eq. (4-2) to calculate the incident heat flux:

$$q''_{\text{incident}}(t) = \frac{1}{\varepsilon} \left(\frac{k[T(d,t) - T_1(t)]}{(L - d)} + \sigma \varepsilon [T(d,t)^4 + T_1(t)^4 - 2T_\infty^4] \right). \quad (4-2)$$

Table 1 defines and describes the variables shown in Eq. (4-2).

Table 1: List of Variables shown in Eq. (4-2)

Variable	Description	Unit	Comment
q''_{incident}	Incident heat flux	$\text{W}\cdot\text{m}^{-2}$	-
t	Time	s	-
ε	Emissivity	-	~ 0.95
k	Thermal conductivity of sensor material	$\text{W}\cdot\text{m}^{-1}\cdot\text{C}^{-1}$	200
L	Thickness of sensor	m	-
d	Depth into sensor where the thermocouple is located	m	-
σ	Stefan-Boltzmann constant	$\text{W}\cdot\text{m}^{-2}\cdot\text{K}^{-4}$	$5.67 \times 10^{-8} \text{ W}\cdot\text{m}^{-2}\cdot\text{K}^{-4}$
ΔT	Differential temperature	$^{\circ}\text{C}$	-
T_∞	Surrounding ambient temperature	$^{\circ}\text{C}$	-
$T_1(t)$	Backside temperature	$^{\circ}\text{C}$	-
$T(d,t)$	Temperature at location d in the sensor	$^{\circ}\text{C}$	-

4.1 Errors

Based on the manufacturer's specifications, the thermocouples have an inherent error of 1.1°C . The actual thermocouple error may be less than 1.1°C as this value represents the limit of error for the entire batch of thermocouples. These limits were used during error analysis to estimate the error in the worst case scenario. The error value is a maximum of 32% for high heat flux measurements (order of $43 \text{ kW}/\text{m}^2$ or higher).

5. Maintenance of the sensor

The following items will help to ensure that the sensor provides accurate temperature measurements for estimation of the heat fluxes:

1. The front face of the aluminum block should be kept clean. Contaminants should be removed with a cloth.
2. Reapply the high-temperature black spray paint as necessary.
3. High temperature tape can be used to keep the M-board insulation in place, if required.
4. If the thermocouples are required to be held in place (in the holes), high temperature cement can be used at the top surface of the block. Ensure that no cement comes in contact with the iron/constantan wires of the thermocouples as well as no cement enters the holes in the aluminum block.

6. Additional Considerations

1. The Thermal Cube does not consist of a cooling fluid. Therefore, users must be careful while handling the device after exposure to heat loads since the cube may still be at an elevated temperature.
2. For repeatability of tests, the stand-off distance between the source of the heat load and the sensor should be maintained constant.

7. Limitation of Liability

Claims for damages (personal and material), in respect of the Thermal Cube, are excluded, if they are due to one or more of the following reasons:

1. Use that is not in accordance with this manual;
2. Improper assembly and incorrect operation;
3. Faulty maintenance;
4. Non-compliance with the assembly and operating installations;
5. Non-approved structural changes to the unit or the individual components;
6. Installation of components which are not a part of the product;

7. Subsequent damage which occurred through further use of the product despite known defects;
8. Intentional damage;
9. *Force majeure* events.

The user will indemnify and hold harmless FPInnovations and the authors of this manual for all losses and damages that occur from use of the thermal cube product that they fabricate.

8. Engineering Drawings [2]

The following are the enclosed engineering drawings for the components of the Thermal Cube:

- i. Aluminum Block
- ii. Thermal Cube Stand: Main Box
- iii. Thermal Cube Stand: Cover
- iv. Thermal Cube Stand: Leg Pole
- v. Thermal Cube Stand: Field Stand
- vi. Thermal Cube Stand: Assembled

8.1 Aluminum Block

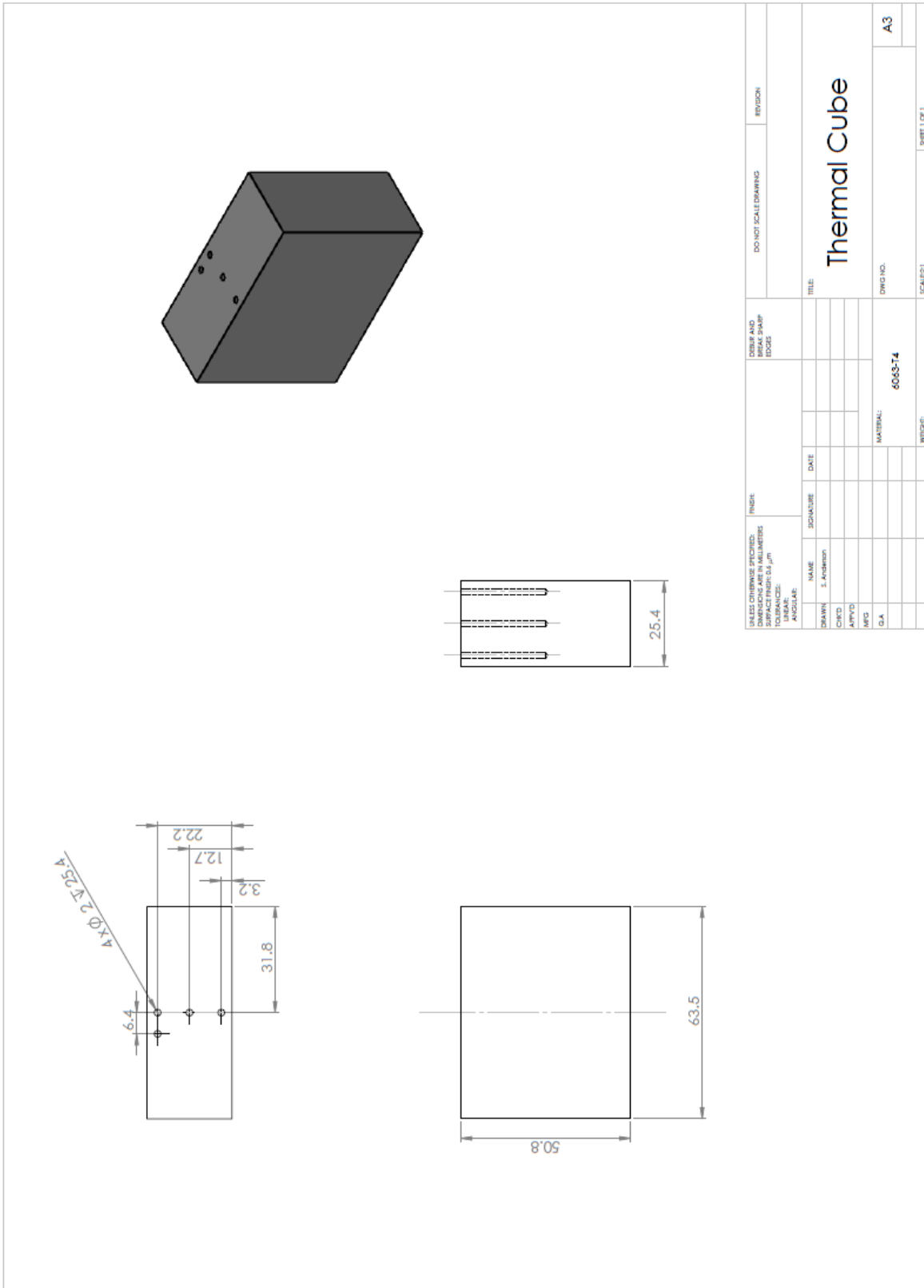

8.2 Main Housing

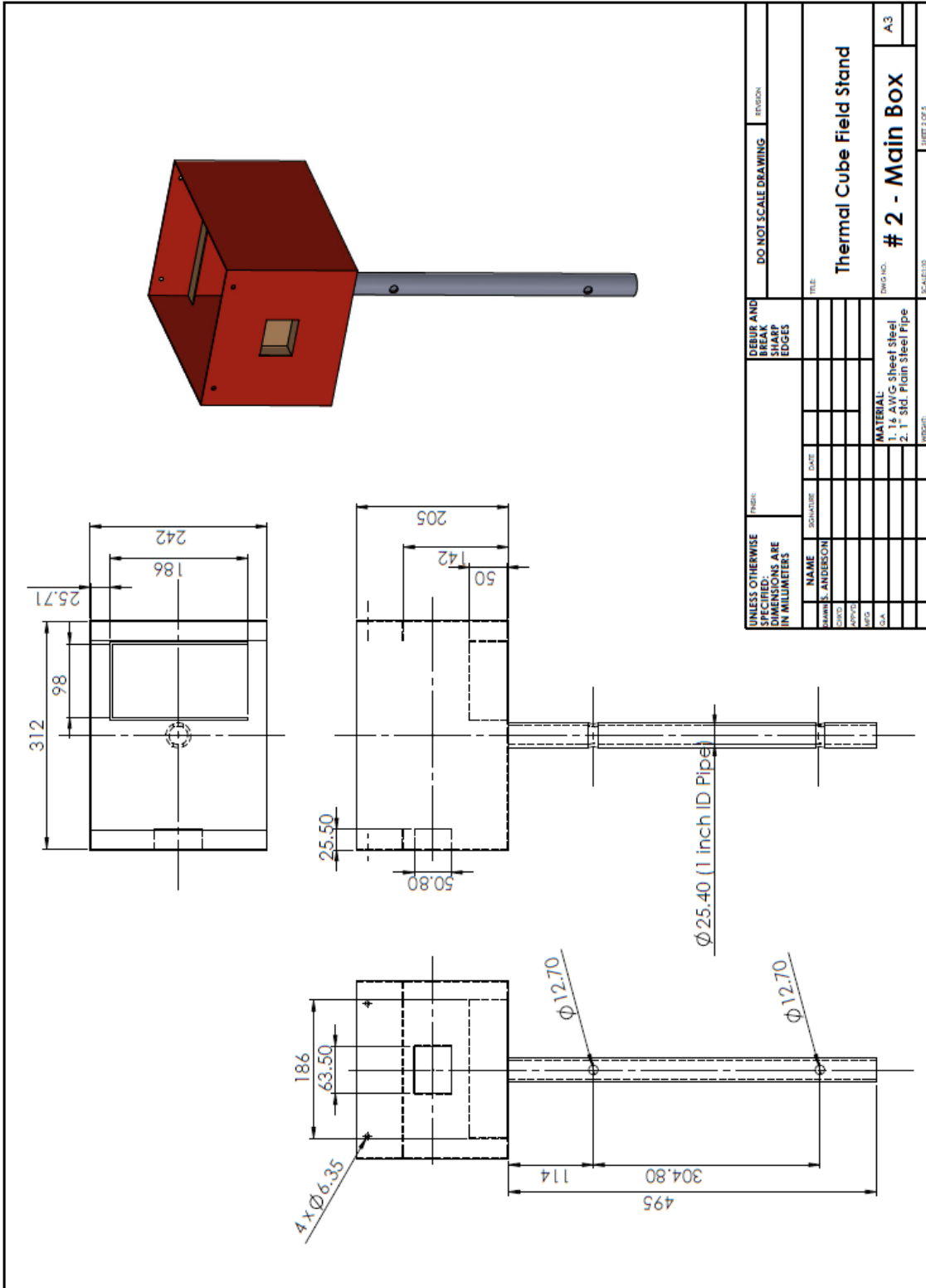

8.3 Cover

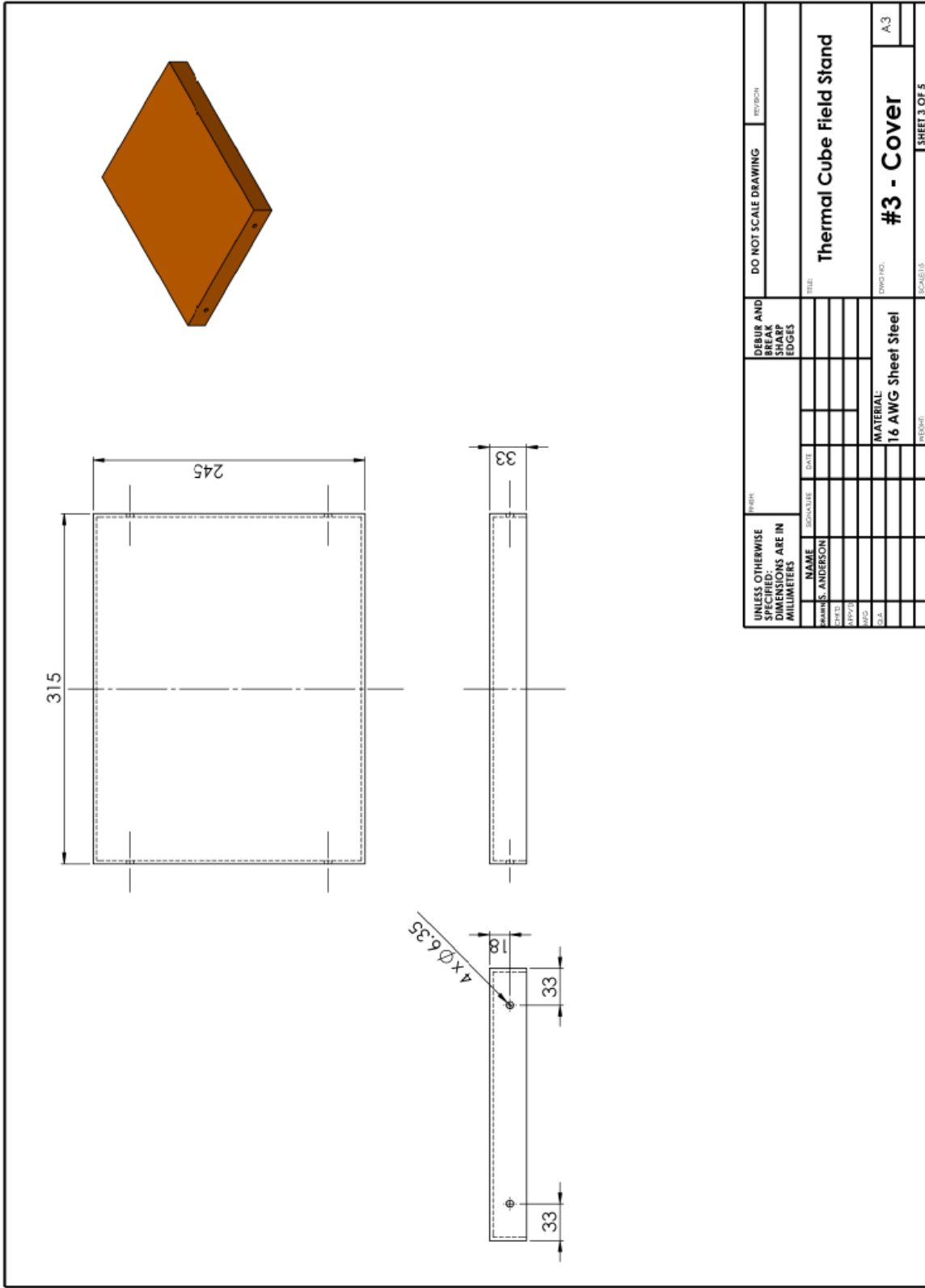

8.4 Leg Pole

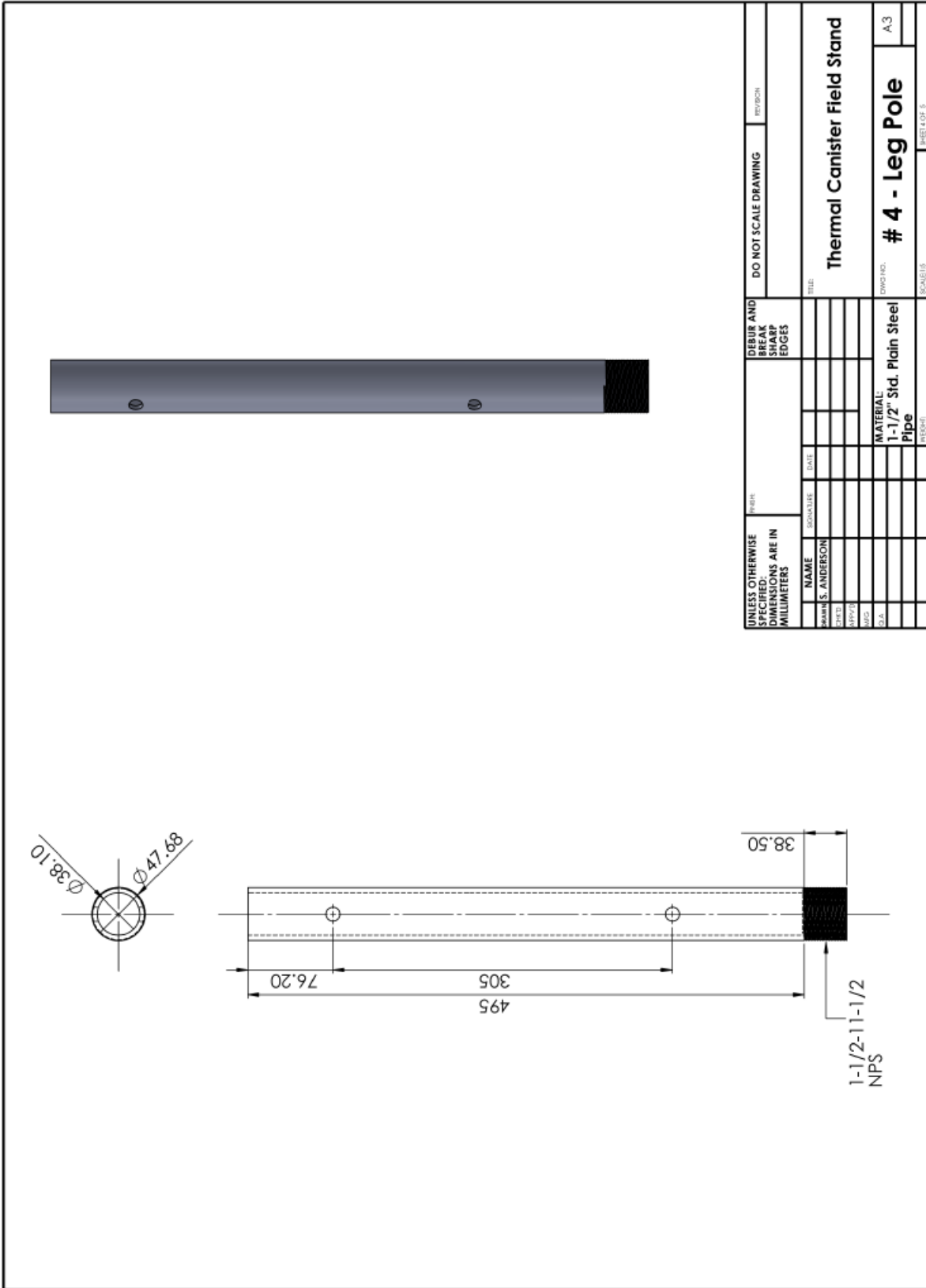

UNLESS OTHERWISE SPECIFIED DIMENSIONS ARE IN MILLIMETERS		FINISH		DEBUR AND REMOVE ALL SHARP EDGES		DO NOT SCALE DRAWING	PROJ/SON
NAME	DATE	DATE	DATE	DATE	DATE	DATE	DATE
MARK S. ANDERSON							
DATE							
APP'D							
DATE							
MATERIAL: 1-1/2" Std. Plain Steel Pipe							Thermal Canister Field Stand
DRAWING NO.							# 4 - Leg Pole
SCALE							A3
SHEET NO.							SHEET 1 OF 1

8.5 Field Stand

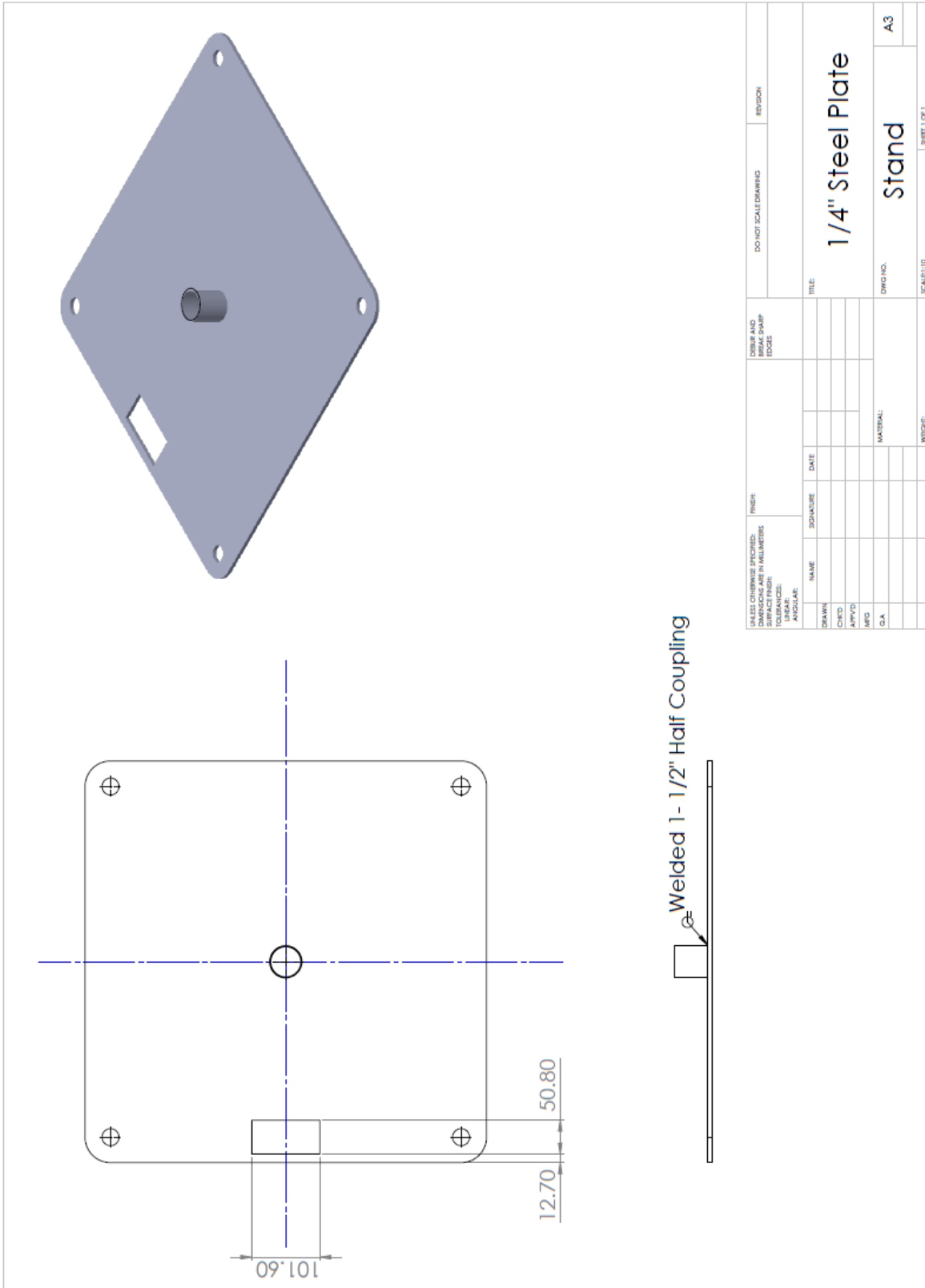

UNLESS OTHERWISE SPECIFIED: DIMENSIONS ARE IN MILLIMETERS DECIMALS IN MILLIMETERS TOLERANCES: FRACTIONS ANGLES:		FINISH	DEBUR AND REMOVE SHARP EDGES		DO NOT SCALE DRAWING	REVISION
DRAWN	NAME	SIGNATURE	DATE	TITLE		
CHKD				1/4" Steel Plate		
APP'D				Stand		
MFG				DWG NO.	A3	
G.A.				SCALE: 1:1		
				MATERIAL:		
				WRODG:		

8.6 Thermal Cube Stand: Assembled

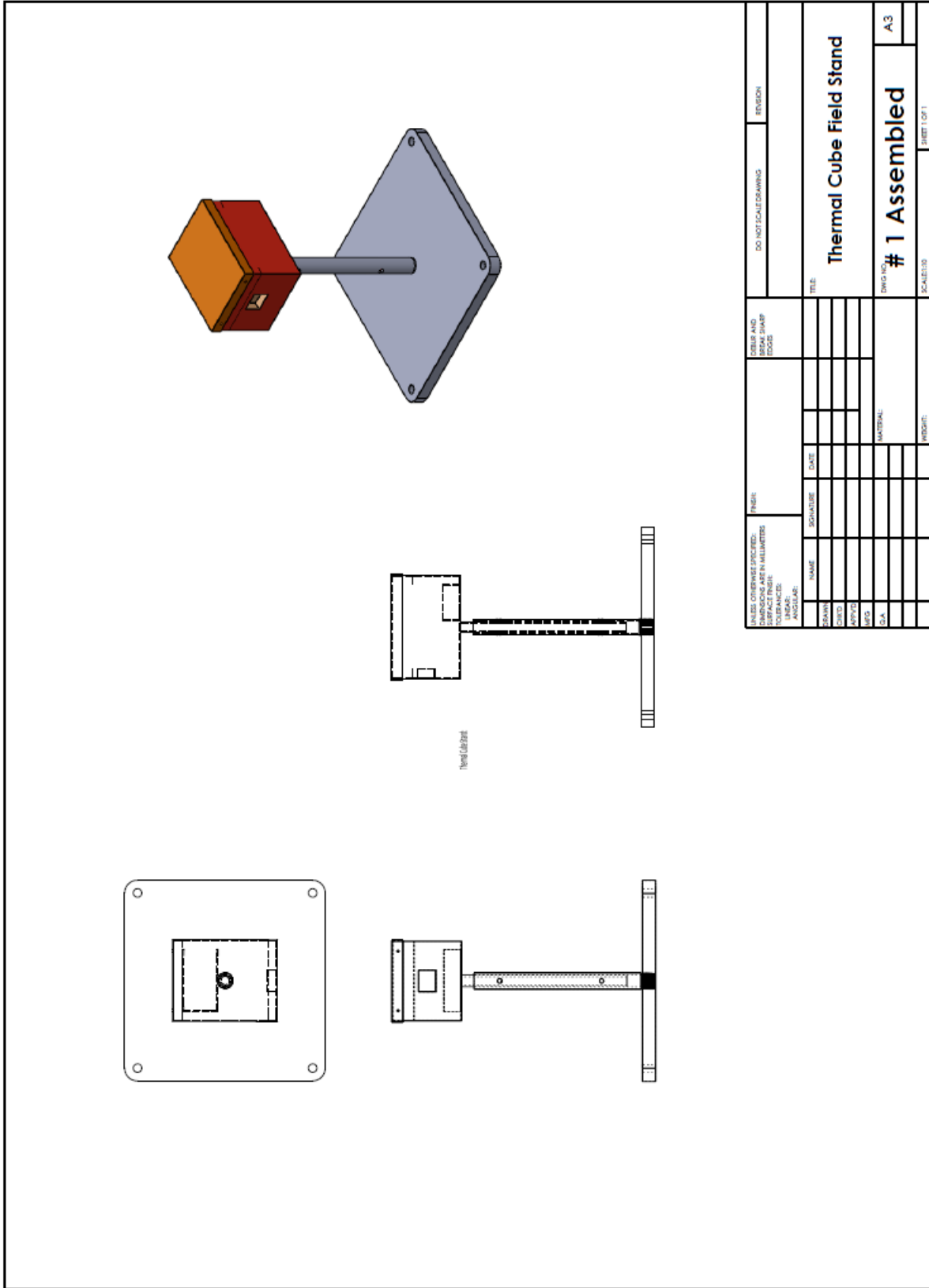

FILE CONVENTIONS (UNITS): DIMENSIONS ARE IN MILLIMETERS SURFACE FINISH: TOLERANCES: FINISH: HATCHING:		TITLE		DO NOT SCALE DRAWING		REVISION	
DESIGNER	DATE	Thermal Cube Field Stand					
DRAWN		# 1 Assembled				A3	
CHECKED						SCALE: 1:10	
APPROVED						SHEET 1 OF 1	
MATERIAL:							
WEIGHT:							

9. Voltage-to-Temperature Conversion

The voltage-to-temperature conversion equation for the J-type thermocouple is:

$$\Delta T = a_0 + a_1 E^2 + a_2 E^3 + a_3 E^4, \quad (9-1)$$

where E is the voltage in microvolts and a_n is the approximation coefficient obtained from calibration data [3], where $n = 0, 1, 2, 3$. If the voltage reading is negative, take its absolute value.

Table 9-1 presents values of a_n that should be used in Eq. (9.1) to find temperatures from voltage readings.

Table 9-1: Approximation coefficients for voltage (μV) to temperature ($^{\circ}\text{C}$) conversion [3]

Temperature Range ($^{\circ}\text{C}$)	a_0	a_1	a_2	a_3	a_4	Error Range ($^{\circ}\text{C}$)
						Exact- Approx.
-200 to 0	0	1.8843850×10^{-2}	$-1.2029733 \times 10^{-6}$	$-2.5278593 \times 10^{-10}$	$-2.5849263 \times 10^{-14}$	-4 to .5
-200 to 760	0	2.1155170×10^{-2}	$-3.3513149 \times 10^{-7}$	$1.2443997 \times 10^{-11}$	$-1.5227150 \times 10^{-16}$	-6 to 7
-200 to 1200	0	2.1676850×10^{-2}	$-2.1844464 \times 10^{-7}$	$3.9094347 \times 10^{-12}$	$-2.4303017 \times 10^{-17}$	-14 to 10
-20 to 500	0	1.9745056×10^{-2}	$-1.8094256 \times 10^{-7}$	$7.8777919 \times 10^{-12}$	$-1.1897222 \times 10^{-16}$	-.07 to .06
0 to 400	0	1.9750953×10^{-2}	$-1.8542600 \times 10^{-7}$	$8.3683958 \times 10^{-12}$	$-1.3280568 \times 10^{-16}$	-.03 to .05
0 to 760	0	1.9323799×10^{-2}	-1.030620×10^{-7}	$3.7084018 \times 10^{-12}$	$-5.1031937 \times 10^{-17}$	-.9 to .7
0 to 1200	0	1.8134974×10^{-2}	$-5.6495930 \times 10^{-8}$	$-2.4644023 \times 10^{-12}$	$2.1141718 \times 10^{-17}$	-3 to 4
400 to 760	9.2808351×10^1	5.4463817×10^{-3}	6.5254537×10^{-7}	$-1.3987013 \times 10^{-11}$	$9.9364476 \times 10^{-17}$	-.03 to .03
400 to 1200	-1.1075293×10^2	2.8651303×10^{-2}	$-2.9758157 \times 10^{-7}$	$2.5945419 \times 10^{-12}$	$-4.9012035 \times 10^{-18}$	-1.3 to 1.6
600 to 760	1.8020713×10^2	$-4.5284199 \times 10^{-3}$	1.0769294×10^{-6}	$-2.1962321 \times 10^{-11}$	$1.5521511 \times 10^{-16}$	-.001 to .001
760 to 1200	-6.3826860×10^2	7.4068749×10^{-2}	$-1.7177773 \times 10^{-6}$	$2.1771293 \times 10^{-11}$	$-9.9502571 \times 10^{-17}$	-.15 to .11

10. References

- [1] E. Sullivan, “Measuring Energy Transfer from Wildland Forest Fires”, University of Alberta, MSc. Thesis, 2014.
- [2] S. Anderson, “Quantification of Performance of Wildfire Chemicals using Custom-Built Heat Flux Sensors,” University of Alberta, MSc. Thesis, 2015.
- [3] R. Powell, W. Hall, C. Hyink, L. Sparks, G. Burns, M. Scorger, H. Plumb, “Thermocouple Reference Tables Based on the IPTS-68,” Stamford, Connecticut, Omega Press, pp. 350.